

FC500 Series Fan-Coil Motorized Valves

FC500 series motorized two-way valves are mainly used to control the opening and closing of cold water and hot water in the terminal of the fan coil units of the air conditioning systems in order to provide a comfortable room temperature. When needed, the motorized valve will automatically turn on after receiving the control signal transmitted from the room temperature controller, then cool or warm the room as required. When temperature reaches the specified value, the room temperature controller will automatically cancel the transmitting signal, and the spring within the motorized valve will force it to turn off and bring it back to the original pre-set value.



Product Features

- Forged brass shell, stainless steel valve stem, and aluminum alloy bracket.
- Permanent magnet synchronous motor with a fully enclosed hysteresis clutch structure and spring reset.
- Synthetic rubber gasket to ensure zero leakage without any bubbles when closed
- Valve body design offers both a 2-way, normally closed type and a 3-way diverter type.
- Motor operates with low power consumption and minimal noise.
- The driver and valve body are separate, enabling quick and easy assembly and disassembly.
- Includes a built-in return spring and an optimized valve core structure.
- Threaded connections follow BSPT and NPT standards.
- Compact size, lightweight.

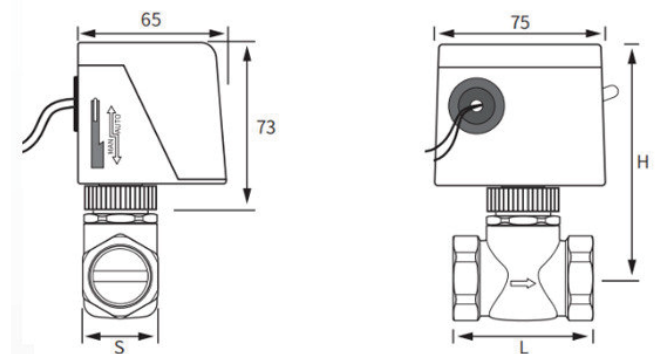

Technical Parameters

Power Supply Voltage: 220 VAC, 24 VAC ±10% 50 Hz

Power: < 6.5 W

Working Pressure: 1.6 Mpa

Medium: Water

Medium Temperature: 5°C ~ 90°C (40°F ~ 194°F)

Ambient Temperature: 0°C ~ 60°C (32°F ~ 140°F)

Action Time: Opening Time 10s, Closing Time 5s

Ingress Protection: IP40

Materials

Body: Brass

Shaft: Stainless Steel

Sealing: NBR or EPDM

Shell: High-strength flame-retardant ABS

Base: Aluminum Alloy

Spring: Stainless Steel

Flow Parameters

Model	Dimension (In)	Structure	Kv value	Differential pressure (MPa)
T215FC500	1/2"	Two-Way	1.0	0.20
T220FC500	3/4"	Two-Way	2.2	0.15
T225FC500	1"	Two-Way	3.5	0.08
T232FC500	1 1/4"	Two-Way	4.2	0.06

Dimensions/Weight

Model	L	H	S	Lbs	Kg
T215FC500	49	94	25.5	1.32	0.60
T220FC500	62	101	32.0	1.65	0.75
T225FC500	70	103	38.0	1.76	0.80
T232FC500	72	115	39.0	1.98	0.90

* Valves should be open when the system is pressurised.